

ITEM NO.	QTY.	PART NUMBER	DESCRIPTION
1	1	1031500N	ASM TK 65HL X 32 NH
2	1	1003700N	ASM 125HL X 32 STAND
3	1	1003800N	ASM 125HL/STAND CONTAINMENT

APPROXIMATE BRIMFUL CAPACITY:
TANK: 72 GAL.
CONTAINMENT: 167.1 GAL.

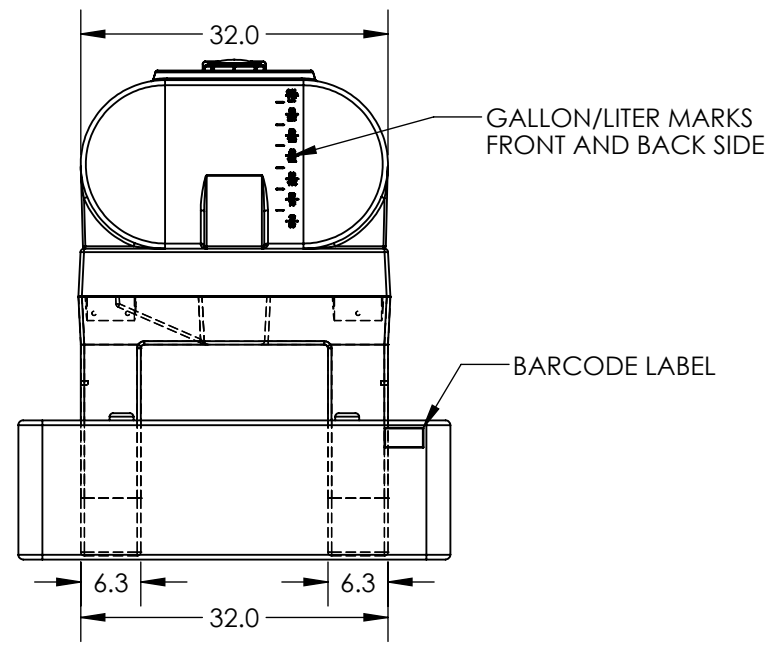
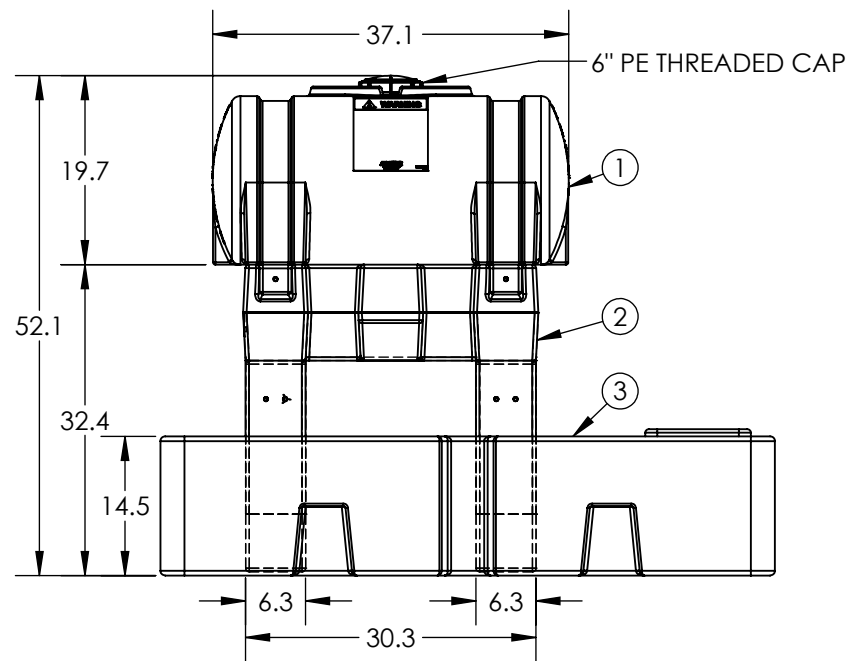
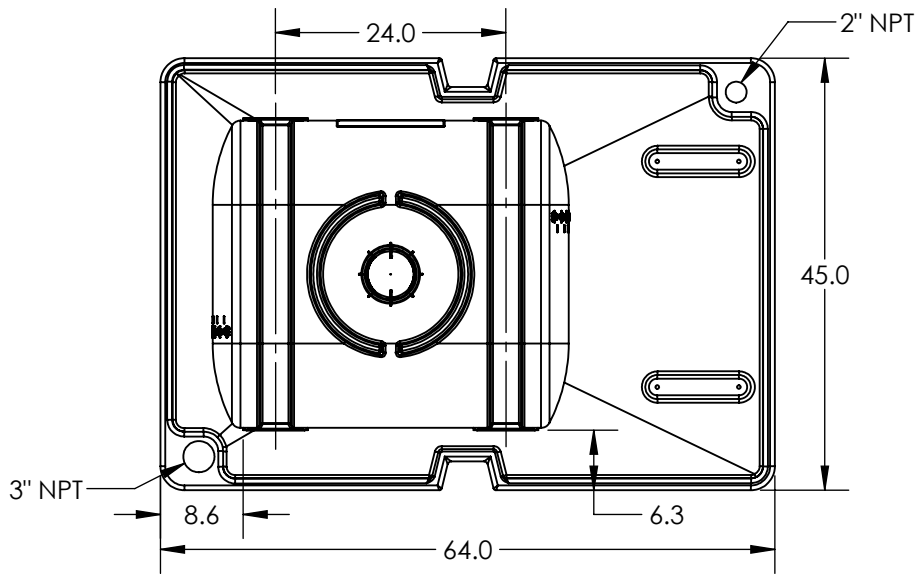

***ALL EXTERNAL PIPING MUST BE INDEPENDENTLY SUPPORTED.**
***ONLY BASE FITTINGS TO BE LEFT INSTALLED AT TIME OF SHIPMENT PER SII PROCEDURE.**
***TANKS ORDERED WITH FOAM INSULATION WILL HAVE AN INCREASED DIAMETER OF 4-6 INCHES.**
***Consult Snyder's Guidelines for Use and Installation prior to delivery.**
Available on-line at <http://www.snyderindustriestanks.com/Technical>
ALL DIMENSIONS ARE IN INCHES, NOMINAL, & SUBJECT TO CHANGE WITHOUT NOTICE.
ALL DIMENSIONS ON ROTATIONAL MOLDED PARTS ARE SUBJECT TO A ± 3% TOLERANCE.

DO NOT SCALE		DRAWN BY	TITLE:		REVISION
STATUS: Released		SB	ASM 65HL/STAND/CONTAINMENT		A
© SNYDER INDUSTRIES, LLC, 2019			PART NO. 1031500N		SHEET 1 OF 1
<small>ALL DIMENSIONS, DESIGNS, AND INFORMATION ON THIS PRINT MUST BE CONSIDERED PROPRIETARY TO SNYDER INDUSTRIES, LLC, AND MAY NOT BE USED, COPIED, OR DISTRIBUTED WITHOUT WRITTEN PERMISSION OF AN OFFICER (OR HIS AGENT) OF THE FIRM.</small>			<small>ENG. ID. D000605</small>		
<small>(402) 467-5221 www.snyderinet.com</small>					